

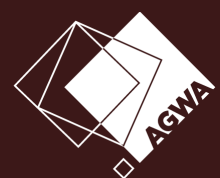

AGWA Guide Series

A GUIDE TO WINDOWS AND DOORS IN BUSHFIRE PRONE AREAS

VERSION 6.2



AUSTRALIAN
**GLASS &
WINDOW**
ASSOCIATION

FOREWORD

As part of its commitment to raising the built performance standard of windows and doors in Australia, the Australian Glass and Window Association (AGWA) is pleased to provide this Industry Guide on the requirements for windows and doors in bushfire prone areas.

In 2018, Australian Standard (AS) 3959 was updated and republished as AS 3959: 2018 Construction of Buildings in Bushfire Prone Areas. The new Standard is primarily concerned with improving the ability of buildings in designated, bushfire prone areas to better withstand attack from bushfire, thus giving a measure of protection to the building occupants and the building itself until the fire front passes. Research is ongoing with regards to the effects of bushfires on buildings, the determination of bushfire prone areas within Australian states and territories, and construction techniques designed to maximise the performance of buildings when subjected to bushfire attack. The outcomes of this research will be reflected in subsequent editions of AS 3959.

This guide outlines the different construction requirements for windows and doors at each Bushfire Attack Level (BAL) as specified by the standard.

AUSTRALIAN GLASS & WINDOW ASSOCIATION (AGWA)

With over 1000 member companies, AGWA is the peak association representing window and glazing manufacturers and their suppliers. It is a cooperative: all members have one vote irrespective of size and financial contribution. The Association Business Plan is monitored and reviewed by an elected Board representing all states and territories of Australia.

AGWA provides a National technical voice through representation on Australian and International Standard

Committees; the Building Code Committee; Residential and Commercial Building Regulation Committees; and Committees for Mandatory Energy Requirements. It keeps the window industry informed via its magazines, website, meetings, conferences and industry exhibitions and promotes the industry through media outlets, trade exhibitions and presentations at industry conferences.

AGWA manages NATA accreditation and compliance programs for manufacturers, provides comprehensive proprietary training and technical support documents through its training division the Australian Fenestration Training Institute (AFTI), handles dispute resolution with consumers and manages the Window Energy Rating Scheme (WERS) that provides the industry with energy ratings for their fenestration systems.

AGWA continues to work relentlessly on all industry issues, representing the industry in as many forums and on as many work groups and committees as they practically can.

DISCLAIMER

This Guide has been developed to provide general guidance, awareness and education to AGWA members, stakeholder groups and consumers. It should not be viewed as a definitive guide. While every effort has been made to ensure the information is accurate, AGWA expressly disclaims all and any liability to any person for anything done in reliance on this publication. No responsibility is accepted by AGWA for any mistakes, errors or omissions in this publication.

This Guide is not a replacement for AS 3959: 2018. For more information refer to AS 3959: 2018 Construction of Buildings in Bushfire Prone Areas.

CONTENTS

FOREWORD	2
AS 3959: 2018	4
Bushfire Attack Levels	4
Compliance Pathways	4
Screens For Windows and Doors	5
Glazing 5	
A Note on BAL-Low	5
REQUIREMENTS	6
BAL-12.5	6
BAL-19	10
BAL-29	12
BAL-40	15
BAL-FZ	18
QUICK REFERENCE GUIDE.....	20
Windows	20
Hinged Doors	22
Sliding Doors	24
ILLUSTRATIONS	26
Decking within horizontal and vertical limits of glazed elements	26
External Walls, glazing or door frames within limits above ground, decks or carport roofs	27
AGWA GUIDE SERIES.....	28

AS 3959: 2018

AS 3959: 2018 - Construction of Buildings in Bushfire Prone Areas is primarily concerned with improving the ability of buildings in designated bushfire prone areas to better withstand attack from bushfire, giving a measure of protection to the building occupants as well as to the building itself.

Under the Standard, all new homes and renovations are assessed and rated to one of six Bushfire Attack Level (BAL) categories ranging from low to flame zone. The BALs are based on heat flux exposure thresholds that measure the amount of energy per square metre of radiant heat exposure. Once the BAL has been determined, specific construction requirements must be followed, ranging from ember protection to direct flame protection.

NOTE: Compliance with both AS 2047 and AS 1288 is required.

BUSHFIRE ATTACK LEVELS

AS 3959 provides a methodology for categorising building sites into one of six levels of severity expressed as Bushfire Attack Levels (BAL). The description of levels of exposure for each BAL is outlined in Table 1.

COMPLIANCE PATHWAYS

AS 3959: 2018 clause 3.8 (General Construction) provides that window and door systems that achieve a level of performance for any given BAL when tested in accordance with AS 1530.8.1, for BAL-12.5 to BAL-40 or AS 1530.8.2 for BAL-FZ, then satisfy the requirements of that BAL.

The Deemed-To-Satisfy (DTS) requirements of Sections 4 to 9 only apply where a system has not been tested.

Table 1 Bushfire Attack Levels

Bushfire Attack Level (BAL)	Description of Predicted Bushfire Attack and Levels of Exposure
BAL-Low	There is insufficient risk to warrant specific construction requirements.
BAL-12.5	Ember attack.
BAL-19	Increasing levels of ember attack and burning debris ignited by windborne embers together with increasing heat flux between 12.5 and 19 kWm ₂ .
BAL-29	Increasing levels of ember attack and burning debris ignited by windborne embers together with increasing heat flux between 19 and 29 kWm ₂ .
BAL-40	Increasing levels of ember attack and burning debris ignited by windborne embers together with increasing heat flux and the increased likelihood of exposure to flames.
BAL-FZ	Direct exposure to flames from fire front in addition to heat flux and ember attack.

AS 3959: 2018

SCREENS FOR WINDOWS AND DOORS

Various provisions within AS 3959 require screening of windows and doors. These requirements can be broadly divided into two categories: radiant heat protection – to reduce the radiant heat load on glazing, or ember protection – to protect openings from burning embers and debris entering.

The provisions for radiant heat protection are primarily associated with low-level glazing, which is glazing within 400 mm of the ground, or other horizontal (or near horizontal) surface. At these locations, where small leaf litter and other flammable debris may accumulate, the window or door system is particularly vulnerable to flame contact and higher radiant heat loads. The purpose of the screening in this instance is to form a barrier to offset direct contact of flames and to attenuate the subsequent radiant heat. Screening used for this purpose must be installed externally, using materials appropriate for the relevant BAL.

Screening is also prescribed by AS 3959 to protect the building from burning embers, which may travel several kilometres ahead of the fire front and attack buildings before the occupants are fully prepared. Windows, which may inadvertently be left open while the property is being prepared, are particularly vulnerable during ember attack. For this reason, it is necessary that all window openings be screened, either internally or externally, using materials appropriate for the relevant BAL. These provisions do not apply to doors.

NOTE: Where a system satisfies the test criteria without screening for ember protection, the requirements of the Standard for screening of the openable parts of windows still applies.

NOTE: Insect screens that are fitted internally, and are completely protected by the closed door, are not required to meet these provisions

GLAZING

Various glass types and thicknesses are prescribed within AS 3959 for the various BALs. In each case, where double glazing is used, the requirements apply to the outer pane only.

A NOTE ON BAL-LOW

BAL-Low is described as having insufficient risk to warrant specific construction requirements. Standard window and door products may be used at this level.

Metal-reinforced uPVC

Clause 1.5.22 Metal-reinforced uPVC states as follows: 'uPVC applied to a continuous metal frame such that if the uPVC fell away no gaps greater than 2 mm would form and the glass pane would continue to be supported.'

What does this mean?

This means that typical uPVC window designs commonly used do not meet the DTS requirements of AS 3959 and have been noted in this Guide.

WINDOWS

BAL-12.5 WINDOWS

OPTION 1: PROTECTED BY A BUSHFIRE SHUTTER

Standard windows can be used provided they are completely protected by bushfire shutters compliant with clauses 3.7 and 5.5.1 of AS 3959.

OPTION 2: TESTED SYSTEM

Window system tested to BAL-12.5 or higher in accordance with AS 1530.8.1. All openable portions of windows must be screened internally or externally with screens that meet the following:

- Mesh or perforated sheet with a maximum aperture of 2 mm manufactured from either:
 - Corrosion resistant steel
 - Bronze
 - Aluminium
- Supporting frame manufactured from either:
 - Metal (includes aluminium) or
 - Bushfire resistant timber or
 - A timber species with a density of at least 650 kg/m³.

OPTION 3: PROTECTED BY A SCREEN

Standard windows can be used provided they are completely protected by external screens that meet the following:

- Mesh or perforated sheet with a maximum aperture of 2 mm manufactured from either:
 - Corrosion resistant steel or
 - Bronze or
 - Aluminium
- Supporting frame manufactured from either:
 - Metal (includes aluminium).
 - Bushfire resistant timber.
 - A timber species with a density of at least 650 kg/m³.

* Refer to metal-reinforced uPVC notes on page 5

** Refer to page 5 for double glazing

BAL-12.5

OPTION 4: DTS REQUIREMENTS

Windows must meet the following:

- Frames
 - If windows are within 400 mm of the ground or other structures within 18 degrees of the horizontal (refer to illustrations on page 26) window frames must be manufactured from either:
 - Metal (includes aluminium).
 - Bushfire resistant timber.
 - A timber species with a density of at least 650 kg/m³.
 - Metal reinforced uPVC.*
- Glazing**
 - All glass within 400 mm of ground or other structures within 18 degrees of the horizontal must be glazed in Grade A safety glass with a minimum 4 mm thickness. (refer to illustrations on page 26). Ordinary annealed glass may be used elsewhere.
- Screens
 - All openable portions of windows must be protected by internal or external screens that meet the following:
 - Mesh or perforated sheet with a maximum aperture of 2 mm manufactured from either:
 - Corrosion resistant steel or
 - Bronze or
 - Aluminium
 - Supporting frame manufactured from either:
 - Metal (includes aluminium) or
 - Bushfire resistant timber
 - A timber species with a density of at least 650 kg/m³.

HINGED DOORS

BAL-12.5 HINGED DOORS

OPTION 1: BUSHFIRE SHUTTERS

Standard hinged doors can be used provided they are completely protected by bushfire shutters compliant with clauses 3.7 and 5.5.1 of AS 3959.

OPTION 2: TESTED SYSTEM

Hinged door system tested to BAL-12.5 or higher in accordance with AS 1530.8.1. The openable portions of hinged doors are not required to be screened, however if fitted externally screens must meet the following:

- Mesh or perforated sheet with a maximum aperture of 2 mm manufactured from either:
 - Corrosion resistant steel or
 - Bronze or
 - Aluminium
- Supporting frame manufactured from either:
 - Metal (includes aluminium) or
 - Bushfire resistant timber or
 - A timber species with a density of at least 650 kg/m³ (refer to Table E2 in the Standard).

OPTION 3: PROTECTED BY A SCREEN

Standard hinged doors can be used provided they are completely protected by external metal mesh screens that meet the following:

- Mesh or perforated sheet with a maximum aperture of 2 mm manufactured from either:
 - Corrosion resistant steel or
 - Bronze or
 - Aluminium
- Supporting frame manufactured from either:
 - Metal (includes aluminium) or
 - Bushfire resistant timber or
 - A timber species with a density of at least 650 kg/m³.

OPTION 4: DTS REQUIREMENTS

Hinged doors must meet the following:

- Frames
 - Door frames must be manufactured from either:
 - Metal (includes aluminium) or
 - Bushfire resistant timber or
 - A timber species with a density of at least 650 kg/m³ or
 - Metal reinforced uPVC.*
- Panels
 - Doors panels must be manufactured from either:
 - Non-combustible materials.
 - Minimum 35 mm thickness solid timber, laminated timber or reconstituted timber for the first 400 mm above threshold.
 - Hollow core, solid timber, laminated timber or reconstituted timber with a non-combustible kick-plate on the outside for the first 400 mm above the threshold.
 - Fully framed glazed door panel with a frame manufactured from either:
 - Metal (includes aluminium) or
 - Bushfire resistant timber or
 - A timber species with a density of at least 650 kg/m³ or
 - Metal reinforced uPVC.*
 - Hinged doors shall be tight fitting in the frame.
- Glazing**
 - All glass must be glazed in Grade A safety glass minimum 4 mm thick.
- Seals
 - Weather-strips, draught excluders or draught seals must be fitted.
- Screens
 - The openable portions of hinged doors are not required to be screened, however if fitted externally screens must meet the following:
 - Mesh or perforated sheet with a maximum aperture of 2 mm manufactured from either:
 - Corrosion resistant steel or
 - Bronze or
 - Aluminium
 - Supporting frame manufactured from either:
 - Metal (including aluminium) or
 - Bushfire resistant timber or
 - A timber species with a density of at least 650 kg/m³.

SLIDING DOORS

BAL-12.5

WINDOWS

BAL-19

BAL-12.5 SLIDING DOORS

OPTION 1: BUSHFIRE SHUTTERS

Standard sliding doors can be used provided they are completely protected by bushfire shutters compliant with clauses 3.7 and 5.5.1 of AS 3959.

OPTION 2: TESTED SYSTEM

Sliding Door system tested to BAL-12.5 or higher in accordance with AS 1530.8.1. The openable portions of sliding doors are not required to be screened, however if fitted externally screens must meet the following:

- Mesh or perforated sheet with a maximum aperture of 2 mm manufactured from either:
 - Corrosion resistant steel or
 - Bronze or
 - Aluminium
- Supporting frame manufactured from either:
 - Metal (including aluminium) or
 - Bushfire resistant timber or
 - A timber species with a density of at least 650 kg/m³.

OPTION 3: PROTECTED BY A SCREEN

Standard sliding doors can be used provided they are completely protected by external metal mesh screens that meet the following:

- Mesh or perforated sheet with a maximum aperture of 2 mm manufactured from either:
 - Corrosion resistant steel or
 - Bronze or
 - Aluminium
- Supporting frame manufactured from either:
 - Metal (includes aluminium) or
 - Bushfire resistant timber or
 - A timber species with a density of at least 650 kg/m³.

OPTION 4: DTS REQUIREMENTS

Sliding doors must meet the following:

- Frames
 - Door frames must be manufactured from either:
 - Metal (includes aluminium) or
 - Bushfire resistant timber or
 - A timber species with a density of at least 650 kg/m³ or
 - Metal reinforced uPVC.*

Sliding door panels shall be tight fitting in the frame.

- Glazing**

All glass must be Grade A safety glass minimum 4 mm thick.

- Screens
- The openable portions of sliding doors are not required to be screened, however if fitted externally screens must meet the following:
 - Mesh or perforated sheet with a maximum aperture of 2 mm manufactured from either:
 - Corrosion resistant steel or
 - Bronze or
 - Aluminium
 - Supporting frame manufactured from either:
 - Metal (including aluminium)
 - Bushfire resistant timber
 - A timber species with a density of at least 650 kg/m³.

NOTE: Insect screens that are fitted internally, and are completely protected by the closed door, are not required to meet these above provisions.

BAL-19 WINDOWS

OPTION 1: BUSHFIRE SHUTTERS

Standard windows can be used provided they are completely protected by bushfire shutters compliant with clauses 3.7 and 6.5.1 of AS 3959.

OPTION 2: TESTED SYSTEM

Window system tested to BAL-19 or higher in accordance with AS 1530.8.1. All openable portions of windows must be screened internally or externally with metal screens that meet the following:

- Mesh or perforated sheet with a maximum aperture of 2 mm manufactured from either:
 - Corrosion resistant steel or
 - Bronze or
 - Aluminium
- Supporting frame manufactured from either:
 - Metal (including aluminium) or
 - Bushfire resistant timber or
 - A timber species with a density of at least 650 kg/m³.

OPTION 3: SCREENS

Standard windows can be used provided they are completely protected by external screens that meet the following:

- Mesh or perforated sheet with a maximum aperture of 2 mm manufactured from either:
 - Corrosion resistant steel or
 - Bronze or
 - Aluminium
- Supporting frame manufactured from either:
 - Metal (including aluminium) or
 - Bushfire resistant timber or
 - A timber species with a density of at least 650 kg/m³.

OPTION 4: DTS REQUIREMENTS

Windows must meet the following:

- Frames
 - If windows are within 400 mm of ground or other structures within 18 degrees of horizontal (refer to illustrations on page 26) window frames must be manufactured from either:
 - Metal (including aluminium) or
 - Bushfire resistant timber or
 - A timber species with a density of at least 650 kg/m³ or
 - Metal reinforced uPVC.*

- Glazing**

All glass within 400 mm of ground or other structures within 18 degrees of the horizontal (refer to illustrations on page 26) must be glazed in toughened safety glass minimum 5 mm. Ordinary annealed glass may be used elsewhere.

NOTE: Where annealed glass is used, it must be screened externally.

- Screens
 - All openable portions of windows must be protected by internal or external screens that meet the following:
 - Mesh or perforated sheet with a maximum aperture of 2 mm manufactured from either:
 - Corrosion resistant steel or
 - Bronze or
 - Aluminium
 - Supporting frame manufactured from either:
 - Metal (including aluminium) or
 - Bushfire resistant timber or
 - A timber species with a density of at least 650 kg/m³.

* Refer to metal-reinforced uPVC notes on page 5

** Refer to page 5 for double glazing

HINGED DOORS

BAL-19

BAL-19 HINGED DOORS

OPTION 1: BUSHFIRE SHUTTERS

Standard hinged doors can be used provided they are completely protected by bushfire shutters compliant with clauses 3.7 and 6.5.1 of AS 3959.

OPTION 2: TESTED SYSTEM

Hinged door system tested to BAL-19 or higher in accordance with AS 1530.8.1. The openable portions of hinged doors are not required to be screened, however if fitted externally screens must meet the following:

- Mesh or perforated sheet with a maximum aperture of 2 mm manufactured from either:
 - Corrosion resistant steel or
 - Bronze or
 - Aluminium
- Supporting frame manufactured from either:
 - Metal (including aluminium) or
 - Bushfire resistant timber or
 - A timber species with a density of at least 650 kg/m³.

OPTION 3: PROTECTED BY A SCREEN

Standard hinged doors can be used provided they are completely protected by external metal screens that meet the following:

- Mesh or perforated sheet with a maximum aperture of 2 mm manufactured from either:
 - Corrosion resistant steel or
 - Bronze or
 - Aluminium
- Supporting frame manufactured from either:
 - Metal (including aluminium) or
 - Bushfire resistant timber or
 - A timber species with a density of at least 650 kg/m³.

* Refer to metal-reinforced uPVC notes on page 5

** Refer to page 5 for double glazing

OPTION 4: DTS REQUIREMENTS

Hinged doors must meet the following:

- Frames
Door frames must be manufactured from either:
 - Metal (including aluminium) or
 - Bushfire resistant timber or
 - A timber species with a density of at least 650 kg/m³ or
 - Metal reinforced uPVC.*
- Panels
Door panels must be manufactured from either:
 - Non-combustible materials or
 - Minimum 35 mm thickness solid timber, laminated timber or reconstituted timber for the first 400 mm above threshold or
 - Hollow core, solid timber, laminated timber or reconstituted timber with a non-combustible kick-plate on the outside for the first 400 mm above the threshold or
 - Fully framed glazed door panel with a frame manufactured from either:
 - Metal (including aluminium) or
 - Bushfire resistant timber or
 - A timber species with a density of at least 650 kg/m³ or
 - Metal reinforced uPVC.*
- Hinged doors shall be tight fitting in the frame.
- Glazing**
All glass must be toughened safety glass minimum 5 mm.
- Seals
Weather-strips, draught excluders or draught seals must be fitted.
- Screens
The openable portions of hinged doors are not required to be screened, however if fitted externally screens must meet the following:
 - Mesh or perforated sheet with a maximum aperture of 2 mm manufactured from either:
 - Corrosion resistant steel or
 - Bronze or
 - Aluminium
 - Supporting frame manufactured from either:
 - Metal (including aluminium) or
 - Bushfire resistant timber or
 - A timber species with a density of at least 650 kg/m³.

SLIDING DOORS

BAL-19

BAL-19 SLIDING DOORS

OPTION 1: BUSHFIRE SHUTTERS

Standard sliding doors can be used provided they are completely protected by bushfire shutters compliant with clauses 3.7 and 6.5.1 of AS 3959.

OPTION 2: TESTED SYSTEM

Sliding door system tested to BAL-19 or higher in accordance with AS 1530.8.1. The openable portions of sliding doors are not required to be screened, however if fitted externally screens must meet the following:

- Mesh or perforated sheet with a maximum aperture of 2 mm manufactured from either:
 - Corrosion resistant steel or
 - Bronze or
 - Aluminium
- Supporting frame manufactured from either:
 - Metal (including aluminium) or
 - Bushfire resistant timber or
 - A timber species with a density of at least 650 kg/m³.

OPTION 3: PROTECTED BY A SCREEN

Standard sliding doors can be used provided they are completely protected by external metal mesh screens that meet the following:

- Mesh or perforated sheet with a maximum aperture of 2 mm manufactured from either:
 - Corrosion resistant steel or
 - Bronze or
 - Aluminium
- Supporting frame manufactured from either:
 - Metal (including aluminium) or
 - Bushfire resistant timber or
 - A timber species with a density of at least 650 kg/m³.

OPTION 4: DTS REQUIREMENTS

Sliding doors must meet the following:

- Frames
Door frames, including fully glazed door panels must be manufactured from either:
 - Metal (including aluminium) or
 - Bushfire resistant timber or
 - A timber species with a density of at least 650 kg/m³ (refer to Table E2 in the Standard).
 - Metal reinforced uPVC.*
- Sliding doors must be tight fitting in the frame.
- Glazing**
All glass must be toughened safety glass minimum 5 mm.
- Screens
The openable portions of sliding doors are not required to be screened, however if fitted externally screens must meet the following:
 - Mesh or perforated sheet with a maximum aperture of 2 mm manufactured from either:
 - Corrosion resistant steel or
 - Bronze or
 - Aluminium
 - Supporting frame manufactured from either:
 - Metal (including aluminium) or
 - Bushfire resistant timber or
 - A timber species with a density of at least 650 kg/m³.

WINDOWS

BAL-29 WINDOWS

OPTION 1: BUSHFIRE SHUTTERS

Standard windows can be used provided they are completely protected by bushfire shutters compliant with clauses 3.7 and 7.5.1 of AS 3959.

OPTION 2: TESTED SYSTEM

Window system tested to BAL-29 or higher in accordance with AS 1530.8.1. All openable portions of windows must be screened internally or externally with metal screens that meet the following:

- Mesh or perforated sheet with a maximum aperture of 2 mm manufactured from either:
 - Corrosion resistant steel or
 - Bronze or
 - Aluminium
- Supporting frame manufactured from either:
 - Metal (including aluminium) or
 - Bushfire resistant timber or
- Screen assemblies must be attached using metal fixings.

OPTION 3: DTS REQUIREMENTS

Windows must meet the following:

- Frames
Window frames must be manufactured from either:
 - Metal (including aluminium) or
 - Bushfire resistant timber or
 - Metal reinforcing uPVC.*
- Hardware
Externally fitted hardware that supports the sash in its function of opening and closing must be manufactured from metal, unless shielded by metal frame components.
- Glazing**
All glass must be toughened safety glass minimum 5 mm.

* Refer to metal-reinforced uPVC notes on page 5

** Refer to page 5 for double glazing

BAL-29

- Screens
All glass within 400 mm of ground or other structures within 18 degrees of the horizontal (refer to illustrations on page 26) must be protected by external screens that meet the following:
 - Mesh or perforated sheet with a maximum aperture of 2 mm manufactured from either:
 - Corrosion resistant steel or
 - Bronze or
 - Aluminium
 - Supporting frame manufactured from either:
 - Metal (including aluminium) or
 - Bushfire resistant timber.
 - All openable portions of windows must be protected by internal or external screens manufactured from:
 - Mesh or perforated sheet with a maximum aperture of 2 mm manufactured from either:
 - Corrosion resistant steel or
 - Bronze or
 - Aluminium
 - A supporting frame manufactured from either:
 - Metal (including aluminium) or
 - Bushfire resistant timber.
- Screen assemblies must be attached using metal fixings.

HINGED DOORS

BAL-29 HINGED DOORS

OPTION 1: BUSHFIRE SHUTTERS

Standard hinged doors can be used provided they are completely protected by bushfire shutters compliant with clauses 3.7 and 7.5.1 of AS 3959 or tested to BAL-29 or higher in accordance with AS 1530.8.1.

OPTION 2: TESTED SYSTEM

Hinged door system tested to BAL-29 or higher in accordance with AS 1530.8.1. The openable portions of hinged doors are not required to be screened, however if fitted externally screens must meet the following:

- Mesh or perforated sheet with a maximum aperture of 2 mm manufactured from either:
 - Corrosion resistant steel or
 - Bronze or
 - Aluminium
- Supporting frame manufactured from either:
 - Metal (including aluminium) or
 - Bushfire resistant timber or
- Screen assemblies must be attached using metal fixings.

OPTION 3: PROTECTED BY A SCREEN

- Standard hinged doors can be used provided they are completely protected by external metal screens that meet the following:
- Mesh or perforated sheet with a maximum aperture of 2 mm manufactured from either:
 - Corrosion resistant steel or
 - Bronze or
 - Aluminium
 - Supporting frame manufactured from either:
 - Metal (including aluminium) or
 - Bushfire resistant timber.
 - Screen assemblies must be attached using metal fixings.

BAL-29

OPTION 4: DTS REQUIREMENTS

Hinged doors must meet the following:

- Frames
Door frames and fully framed glazed door panels must be manufactured from:
 - Metal (including aluminium) or
 - Bushfire resistant timber or
 - Metal reinforced uPVC.*
- Panels
Doors shall be manufactured of either:
 - Non-combustible materials or
 - Minimum 35 mm thickness solid timber, laminated timber or reconstituted timber for the first 400 mm above threshold.Fully framed glazed door panel with a frame manufactured from either:
 - Metal (including aluminium) or
 - Bushfire resistant timber or
 - Metal reinforced uPVC.*Hinged doors shall be tight fitting in the frame.
- Hardware
Externally fitted hardware that supports the door panel in its function of opening and closing must be manufactured from metal.
- Glazing**
All glass must be toughened safety glass minimum 6 mm.
- Seals
Weather strips, draught excluders or draught seals must be fitted.
- Screens
The openable portions of hinged doors are not required to be screened, however if fitted externally screens must meet the following:
 - Mesh or perforated sheet with a maximum aperture of 2 mm manufactured from either:
 - Corrosion resistant steel or
 - Bronze or
 - Aluminium.
 - Supporting frame manufactured from either:
 - Metal (including aluminium) or
 - Bushfire resistant timber
 - Screen assemblies must be attached using metal fixings.

SLIDING DOORS

BAL-29

WINDOWS

BAL-40

BAL-29 SLIDING DOORS

OPTION 1: BUSHFIRE SHUTTERS

Standard sliding doors can be used provided they are completely protected by bushfire shutters compliant with clauses 3.7 and 7.5.1 of AS 3959 or tested to BAL-29 or higher in accordance with AS 1530.8.1.

OPTION 2: TESTED SYSTEM

Sliding door system tested to BAL-29 or higher in accordance with AS 1530.8.1. The openable portions of sliding doors are not required to be screened, however if fitted externally screens must meet the following:

- Mesh or perforated sheet with a maximum aperture of 2 mm manufactured from either:
 - Corrosion resistant steel or
 - Bronze or
 - Aluminium
- Supporting frame manufactured from either:
 - Metal (including aluminium) or
 - Bushfire resistant timber or
- Screen assemblies must be attached using metal fixings.

OPTION 3: PROTECTED BY A SCREEN

Standard hinged doors can be used provided they are completely protected by external metal mesh screens that meet the following:

- Mesh or perforated sheet with a maximum aperture of 2 mm manufactured from either:
 - Corrosion resistant steel or
 - Bronze or
 - Aluminium
- Supporting frame manufactured from either:
 - Metal (including aluminium) or
 - Bushfire resistant timber or
- Screen assemblies must be attached using metal fixings.

OPTION 4: DTS REQUIREMENTS

Sliding doors must meet the following:

- Frames
 - Door frames, including fully glazed door panels must be manufactured from either:
 - Metal (including aluminium) or
 - Bushfire resistant timber or
 - Metal reinforced uPVC.*
 - Sliding doors shall be tight fitting in the frame.
- Hardware
 - Externally fitted hardware that supports the sash in its function of opening and closing must be manufactured from metal.
- Glazing**
 - All glass must be toughened safety glass minimum 6 mm.
- Screens
 - The openable portions of sliding doors are not required to be screened, however if fitted externally screens must meet the following:
- Mesh or perforated sheet with a maximum aperture of 2 mm manufactured from either:
 - Corrosion resistant steel or
 - Bronze or
 - Aluminium
- Supporting frame manufactured from either:
 - Metal (including aluminium) or
 - Bushfire resistant timber.
- Screen assemblies must be attached using metal fixings

BAL-40 WINDOWS

OPTION 1: BUSHFIRE SHUTTERS

Standard windows can be used provided they are completely protected by bushfire shutters compliant with clauses 3.7 and 8.5.1 of AS 3959 or tested to BAL-40 or higher in accordance with AS 1530.8.1.

OPTION 2: TESTED SYSTEM

Window system tested to BAL-40 or higher in accordance with AS 1530.8.1. All openable portions of windows must be screened internally or externally with metal screens that meet the following:

- Mesh or perforated sheet with a maximum aperture of 2 mm manufactured from either:
 - Corrosion resistant steel or
 - Bronze
- Supporting frame manufactured from metal (including aluminium).
- Screen assemblies must be attached using metal fixings.

OPTION 3: DTS REQUIREMENTS

Windows must meet the following:

- Frames
 - Window frames shall be manufactured from metal (including aluminium).
- Hardware
 - Externally fitted hardware that supports the sash in its function of opening and closing must be manufactured from metal.
- Glazing**
 - All glass must be toughened safety glass minimum 6 mm.
- Seals
 - Seals applied to stiles, head and sills or thresholds shall be manufactured from silicone or a material having a flammability index no greater than 5.
- Screens
 - Both the fixed and openable portions of windows must be protected by external screens that meet the following:
- Mesh or perforated sheet with a maximum aperture of 2 mm manufactured from either:
 - Corrosion resistant steel or
 - Bronze or
- Supporting frame manufactured from metal (including aluminium).
- Screen assemblies must be attached using metal fixings.

* Refer to metal-reinforced uPVC notes on page 5

** Refer to page 5 for double glazing

HINGED DOORS

BAL-40 HINGED DOORS

OPTION 1: BUSHFIRE SHUTTERS

Standard hinged doors can be used provided they are completely protected by bushfire shutters compliant with clauses 3.7 and 8.5.1 of AS 3959 or tested to BAL-40 or higher in accordance with AS 1530.8.1.

OPTION 2: TESTED SYSTEM

Hinged door system tested to BAL-40 or higher in accordance with AS 1530.8.1. The openable portions of hinged doors are not required to be screened, however if fitted externally screens must meet the following:

- Mesh or perforated sheet with a maximum aperture of 2 mm manufactured from either:
 - Corrosion resistant steel or
 - Bronze
- Supporting frame manufactured from metal (including aluminium).
- Screen assemblies must be attached using metal fixings.

OPTION 3: DTS REQUIREMENTS

Hinged doors must meet the following:

- Frames
Door frames must be manufactured from metal (including aluminium)
- Panels
Door panels manufactured from:
 - Non-combustible materials: or
 - Minimum 35 mm thickness solid timber, laminated timber or reconstituted timber for the first 400 mm above threshold and protected externally by a screen that must meet the following:
 - Mesh or perforated sheet with a maximum aperture of 2 mm manufactured from either:
 - » Corrosion resistant steel or
 - » Bronze
 - Supporting frame manufactured from metal (including aluminium).
 - Screen assemblies must be attached using metal fixings.
 - Fully framed glazed door panel with a frame manufactured from metal (including aluminium)
Hinged doors shall be tight fitting in the frame.

** Refer to page 5 for double glazing

BAL-40

- Hardware
Externally fitted hardware that supports the door panel in its function of opening and closing must be manufactured from metal.
- Glazing**
All glass must be toughened safety glass minimum 6 mm.
- Seals
Weather-strips, draught excluders or draught seals must be fitted. Seals to stiles, heads and sills must be manufactured from silicone or a material having a flammability index no greater than 5.
- Screens
Glazing must be protected by external screens that meet the following:
 - Mesh or perforated sheet with a maximum aperture of 2 mm manufactured from either:
 - Corrosion resistant steel or
 - Bronze.Supporting frame manufactured from metal (including aluminium).
The openable portions of hinged doors are not required to be screened, however if fitted externally screens must meet the following:
 - Mesh or perforated sheet with a maximum aperture of 2 mm manufactured from either:
 - Corrosion resistant steel
 - Bronze
 - Supporting frame manufactured from metal (including aluminium).
 - Screen assemblies must be attached using metal fixings.

SLIDING DOORS

BAL-40 SLIDING DOORS

OPTION 1: BUSHFIRE SHUTTERS

Standard sliding doors can be used provided they are completely protected by bushfire shutters compliant with clauses 3.7 and 8.5.1 of AS 3959 or tested to BAL-40 or higher in accordance with AS 1530.8.1.

OPTION 2: TESTED SYSTEM

Sliding door system tested to BAL-40 in accordance with AS 1530.8.1. The openable portions of hinged doors are not required to be screened, however if fitted externally screens must meet the following:

- Mesh or perforated sheet with a maximum aperture of 2 mm manufactured from either:
 - Corrosion resistant steel or
 - Bronze
- Supporting frame manufactured from metal (including aluminium).
- Screen assemblies must be attached using metal fixings.

OPTION 3: DTS REQUIREMENTS

Sliding doors must meet the following:

- Frames
Door frames, including fully glazed door panels must be manufactured from metal (including aluminium). Sliding doors shall be tight fitting in the frame.
- Hardware
Externally fitted hardware that supports the sash in its function of opening and closing must be manufactured from metal.
- Glazing**
All glass must be toughened safety glass minimum 6 mm.
- Seals
Seals to stiles, heads and sills must be manufactured from silicone or a material having a flammability index no greater than 5.

- Screens
Glazing in both the fixed and openable portions of sliding doors must be protected by external screens that meet the following:
 - Mesh or perforated sheet with a maximum aperture of 2 mm manufactured from either:
 - Corrosion resistant steel or
 - Bronze
 - A supporting frame manufactured from metal (including aluminium)
 - Screen assemblies must be attached using metal fixings.

WINDOWS

HINGED DOORS BAL-FZ

SLIDING DOORS

BAL-FZ

BAL-FZ WINDOWS

OPTION 1: BUSHFIRE SHUTTERS

Standard windows can be used provided they are completely protected by bushfire shutters compliant with clauses 3.7, except that perforations are not permissible, and tested to in accordance with AS 1530.8.2.

OPTION 2: TESTED SYSTEM

Window system tested to BAL-FZ in accordance with AS 1530.8.2 or have and FRL of at least -/30/-. All openable portions of windows must be screened internally or externally with metal screens with:

- Mesh or perforated sheet with a maximum aperture of 2 mm manufactured from either:
 - Corrosion resistant steel or
 - Bronze
- Supporting frame manufactured from metal (including aluminium).
- Screen assemblies must be attached using metal fixings.

HINGED DOORS

OPTION 1: BUSHFIRE SHUTTERS

Standard hinged doors can be used provided they are completely protected by bushfire shutters compliant with clauses 3.7, except that perforations are not permissible, and tested to in accordance with AS 1530.8.2.

OPTION 2: TESTED SYSTEM

Door system tested to BAL-FZ in accordance with AS 1530.8.2 or have and FRL of at least -/30/- and:

- Doors must be tight fitting in the frame and to an abutting door.
- Weather strips, draught excluders or draught seals must be installed at the base of hinged doors.
- Seals must not compromise the FRL or the performance achieved under AS 1530.4.

BAL-FZ SLIDING DOORS

OPTION 1: BUSHFIRE SHUTTERS

Standard sliding doors can be used provided they are completely protected by bushfire shutters compliant with clauses 3.7, except that perforations are not permissible, and tested to in accordance with AS 1530.8.2.

OPTION 2: TESTED SYSTEM

Sliding door system tested to in accordance with AS 1530.8.2 or have and FRL of at least -/30/- and doors must be tight fitting in the frame.

QUICK REFERENCE GUIDE

DTS PROVISIONS FOR WINDOWS

	BAL-12.5	BAL-19	BAL-29	BAL-40
Frame	Low-level framing must be manufactured from either: <ul style="list-style-type: none"> • Metal, or • Bushfire resistant timber or • Timber species with a density greater than 650 kg/m₃ or • Metal reinforced uPVC.* 	Low-level framing must be manufactured from either: <ul style="list-style-type: none"> • Metal, or • Bushfire resistant timber or • Timber species with a density greater than 650 kg/m₃ or • Metal reinforced uPVC.* 	Low-level framing must be manufactured from either: <ul style="list-style-type: none"> • Metal, or • Bushfire resistant timber or • Metal reinforced uPVC.* 	All framing must be metal.
Glazing**	Low-level glazing must be Grade A safety glass with a minimum thickness of 4 mm.	Low-level glazing must be Grade A safety glass with a minimum thickness of 5 mm. In all other locations where annealed glass is used, it must be protected by an external screen (see screen requirements).	All glazing must be toughened glass with a minimum thickness of 5 mm. Low-level glazing must be protected by an external screen (see screen requirements).	All glazing must be toughened glass with a minimum thickness of 6 mm. All glazing must be protected by an external screen (see screen requirements).
Screens	Openable portions of windows must be screened either internally or externally. Mesh or perforated sheet with a maximum aperture of 2mm manufactured from either: <ul style="list-style-type: none"> • Corrosion resistant steel, or • Bronze, or • Aluminium Supporting frame must be manufactured from either: <ul style="list-style-type: none"> • Metal (including aluminium), or • Bushfire resistant timber or • Timber species with a density greater than 650 kg/m₃. 	Openable portions of windows must be screened either internally or externally. Mesh or perforated sheet with a maximum aperture of 2 mm manufactured from either: <ul style="list-style-type: none"> • Corrosion resistant steel, or • Bronze, or • Aluminium Supporting frame must be manufactured from either: <ul style="list-style-type: none"> • Metal (including aluminium), or • Bushfire resistant timber or • Timber species with a density greater than 650 kg/m₃. Where annealed glass is used, it must be protected by an external screen.	Openable portions of windows must be screened either internally or externally. Mesh or perforated sheet with a maximum aperture of 2 mm manufactured from either: <ul style="list-style-type: none"> • Corrosion resistant steel, or • Bronze, or • Aluminium Supporting frame must be manufactured from either: <ul style="list-style-type: none"> • Metal (including aluminium), or • Bushfire resistant timber. Low-level glazing must be protected by an external screen. Screen assemblies must be attached using metal fixings.	Fixed and openable portions of windows must be screened externally. Mesh or perforated sheet with a maximum aperture of 2 mm manufactured from either: <ul style="list-style-type: none"> • Corrosion resistant steel, or • Bronze. Aluminium mesh or perforated sheet cannot be used. Supporting frame must be manufactured from metal (including aluminium). Screen assemblies must be attached using metal fixings.
Seals	N/A	N/A	N/A	N/A
Hardware	N/A	N/A	Externally fitted hardware that supports the sash in its functions of opening and closing must be metal unless shielded by metal frame components.	Externally fitted hardware that supports the sash in its functions of opening and closing, must be metal.

NOTES

Where double-glazed units are used, the glazing requirements provided in this Standard apply to the external face of the window assembly only.

Low-level glazing is any glass within 400 mm of the ground, decks, carport roofs, awnings or similar horizontal (or near horizontal) elements.

* Refer to metal-reinforced uPVC notes on page 5

** Refer to page 5 for double glazing

QUICK REFERENCE GUIDE

DTS PROVISIONS FOR HINGED DOORS

	BAL-12.5	BAL-19	BAL-29	BAL-40
Frame	<p>Door frames must be manufactured from either:</p> <ul style="list-style-type: none"> • Metal, or • Bushfire resistant timber or • Timber species with a density greater than 650 kg/m₃ or • Metal reinforced uPVC.* <p>Fully framed glass door panels must be manufactured from either:</p> <ul style="list-style-type: none"> • Metal, or • Bushfire resistant timber or • Timber species with a density greater than 650 kg/m₃ or • Metal reinforced uPVC.* • Door panels must be tight fitting in the frames. 	<p>Door frames must be manufactured from either:</p> <ul style="list-style-type: none"> • Metal, or • Bushfire resistant timber or • Timber species with a density greater than 650 kg/m₃ or • Metal reinforced uPVC.* <p>Fully framed glass door panels must be manufactured from either:</p> <ul style="list-style-type: none"> • Metal, or • Bushfire resistant timber or • Timber species with a density greater than 650 kg/m₃ or • Metal reinforced uPVC.* • Door panels must be tight fitting in the frames. 	<p>Door frames must be manufactured from either:</p> <ul style="list-style-type: none"> • Metal, or • Bushfire resistant timber or • Metal reinforced uPVC.* <p>Fully framed glass door panels must be manufactured from either:</p> <ul style="list-style-type: none"> • Metal, or • Bushfire resistant timber or • Metal reinforced uPVC.* • Door panels must be tight fitting in the frames 	<p>All panels and framing must be metal.</p> <p>Door panels must be tight fitting in the frames.</p>
Glazing**	All glazing must be Grade A safety glass with a minimum thickness of 4 mm.	All glazing must be toughened glass with a minimum thickness of 5 mm.	All glazing must be toughened glass with a minimum thickness of 6 mm.	<p>All glazing must be toughened glass with a minimum thickness of 6 mm.</p> <p>All glazing must be protected by an external screen (see screen requirements).</p>
Screens	<p>Openable portions of hinged doors are not required to be screened. However, if screens are fitted externally, they must be manufactured from:</p> <ul style="list-style-type: none"> • Mesh or perforated sheet with a maximum aperture of 2 mm manufactured from either: <ul style="list-style-type: none"> • Corrosion resistant steel, or • Bronze, or • Aluminium • Supporting frame must be manufactured from either: <ul style="list-style-type: none"> • Metal (including aluminium), or • Bushfire resistant timber (Table E1), or • Timber species with a density greater than 650 kg/m₃ (Table E2). 	<p>Openable portions of hinged doors are not required to be screened. However, if screens are fitted externally, they must be manufactured from:</p> <ul style="list-style-type: none"> • Mesh or perforated sheet with a maximum aperture of 2 mm manufactured from either: <ul style="list-style-type: none"> • Corrosion resistant steel, or • Bronze, or • Aluminium • Supporting frame must be manufactured from either: <ul style="list-style-type: none"> • Metal (including aluminium), or • Bushfire resistant timber (Table E1), or • Timber species with a density greater than 650 kg/m₃ (Table E2). 	<p>Openable portions of hinged doors are not required to be screened. However, if screens are fitted externally, they must be manufactured from:</p> <ul style="list-style-type: none"> • Mesh or perforated sheet with a maximum aperture of 2 mm manufactured from either: <ul style="list-style-type: none"> • Corrosion resistant steel, or • Bronze, or • Aluminium • Supporting frame must be manufactured from either: <ul style="list-style-type: none"> • Metal (including aluminium), or • Bushfire resistant timber (Table E1). • Screen assemblies must be attached using metal fixings. 	<p>Openable portions of hinged doors are not required to be screened. However, all glazing must be protected by screens fitted external, which must be manufactured from:</p> <ul style="list-style-type: none"> • Mesh or perforated sheet with a maximum aperture of 2 mm manufactured from either: <ul style="list-style-type: none"> • Corrosion resistant steel, or • Bronze. • Aluminium mesh or perforated sheet cannot be used. • Supporting frame must be manufactured from metal (including aluminium). • Screen assemblies must be attached using metal fixings.
Seals	Weather strips, draught excluders or draught seals must be fitted.	Weather-strips, draught excluders or draught seals must be fitted.	Weather-strips, draught excluders or draught seals must be fitted.	<p>Weather-strips, draught excluders or draught seals must be fitted.</p> <p>Seals must be manufactured from silicone or have a flammability index of less than 5.</p>
Hardware	N/A	N/A	Externally fitted hardware that supports the door panel in its functions of opening and closing, must be metal.	Externally fitted hardware that supports the door panel in its functions of opening and closing, must be metal.

NOTES

Where double-glazed units are used, the glazing requirements provided in this Standard apply to the external face of the window assembly only.

Low-level glazing is any glass within 400 mm of the ground, decks, carport roofs, awnings or similar horizontal (or near horizontal) elements.

* Refer to metal-reinforced uPVC notes on page 5

** Refer to page 5 for double glazing

	BAL-12.5	BAL-19	BAL-29	BAL-40
Frame	<p>Door frames must be manufactured from either:</p> <ul style="list-style-type: none"> • Metal, or • Bushfire resistant timber or • Timber species with a density greater than 650 kg/m₃ or • Metal reinforced uPVC.* <p>Door panels must be tight fitting in the frames.</p>	<p>Door frames must be manufactured from either:</p> <ul style="list-style-type: none"> • Metal, or • Bushfire resistant timber or • Timber species with a density greater than 650 kg/m₃ or • Metal reinforced uPVC.* <p>Door panels must be tight fitting in the frames.</p>	<p>Door frames must be manufactured from either:</p> <ul style="list-style-type: none"> • Metal, or • Bushfire resistant timber or • Metal reinforced uPVC.* <p>Door panels must be tight fitting in the frames.</p>	<p>All framing must be metal.</p> <p>Door panels must be tight fitting in the frames.</p>
Glazing**	<p>All glazing must be Grade A safety glass with a minimum thickness of 4 mm.</p>	<p>All glazing must be toughened glass with a minimum thickness of 5 mm.</p>	<p>All glazing must be toughened glass with a minimum thickness of 6 mm.</p>	<p>All glazing must be toughened glass with a minimum thickness of 6 mm.</p>
Screens	<p>Openable portions of sliding doors are not required to be screened. However, if screens are fitted externally, they must be manufactured from:</p> <ul style="list-style-type: none"> • Mesh or perforated sheet with a maximum aperture of 2 mm manufactured from either: <ul style="list-style-type: none"> • Corrosion resistant steel, or • Bronze, or • Aluminium • Supporting frame must be manufactured from either: <ul style="list-style-type: none"> • Metal (including aluminium), or • Bushfire resistant timber or • Timber species with a density greater than 650 kg/m₃. 	<p>Openable portions of sliding doors are not required to be screened. However, if screens are fitted externally, they must be manufactured from:</p> <ul style="list-style-type: none"> • Mesh or perforated sheet with a maximum aperture of 2 mm manufactured from either: <ul style="list-style-type: none"> • Corrosion resistant steel, or • Bronze, or • Aluminium • Supporting frame must be manufactured from either: <ul style="list-style-type: none"> • Metal (including aluminium), or • Bushfire resistant timber or • Timber species with a density greater than 650 kg/m₃. 	<p>Openable portions of sliding doors are not required to be screened. However, if screens are fitted externally, they must be manufactured from:</p> <ul style="list-style-type: none"> • Mesh or perforated sheet with a maximum aperture of 2 mm manufactured from either: <ul style="list-style-type: none"> • Corrosion resistant steel, or • Bronze, or • Aluminium • Supporting frame must be manufactured from either: <ul style="list-style-type: none"> • Metal (including aluminium), or • Bushfire resistant timber. • Screen assemblies must be attached using metal fixings. 	<p>The fixed and openable portions of sliding doors must be protected by an external screen.:</p> <ul style="list-style-type: none"> • Mesh or perforated sheet with a maximum aperture of 2 mm manufactured from either: <ul style="list-style-type: none"> • Corrosion resistant steel, or • Bronze. • Aluminium mesh or perforated sheet cannot be used. • Supporting frame must be manufactured from metal (including aluminium). • Screen assemblies must be attached using metal fixings.
Seals	N/A	N/A	N/A	Seals must be manufactured from silicone or have a flammability index of less than 5.
Hardware	N/A	N/A	Externally fitted hardware that supports the door panel in its functions of opening and closing, must be metal.	Externally fitted hardware that supports the door panel in its functions of opening and closing, must be metal.

NOTES

Where double-glazed units are used, the glazing requirements provided in this Standard apply to the external face of the window assembly only.

Low-level glazing is any glass within 400 mm of the ground, decks, carport roofs, awnings or similar horizontal (or near horizontal) elements.

* Refer to metal-reinforced uPVC notes on page 5

** Refer to page 5 for double glazing

ILLUSTRATIONS

DECKING WITHIN HORIZONTAL AND VERTICAL LIMITS OF GLAZED ELEMENTS

Figure 1 Plan View
Decking less than 300 mm from glazed element (measured horizontally at deck level).

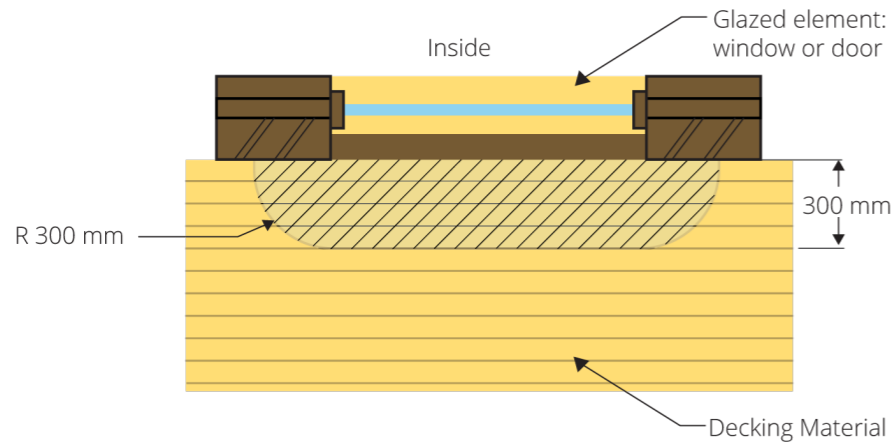
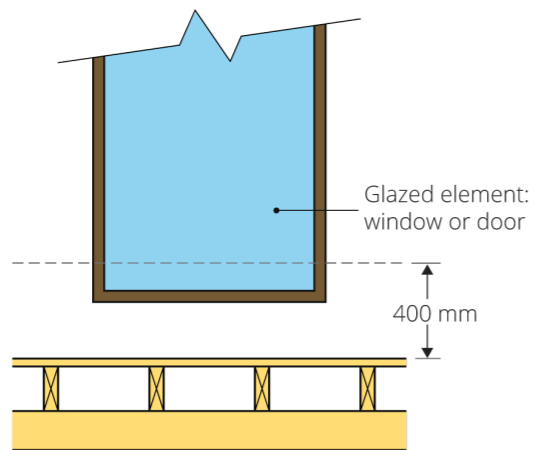

Figure 2 Elevation View
Decking less than 400 mm from glazed element (measured vertically from the surface of the deck).



ILLUSTRATIONS

EXTERNAL WALLS, GLAZING OR DOOR FRAMES WITHIN LIMITS ABOVE GROUND, DECKS OR CARPORT ROOFS

Figure 3 Construction requirements for external walls, glazing or door joinery within 400 mm of ground level.

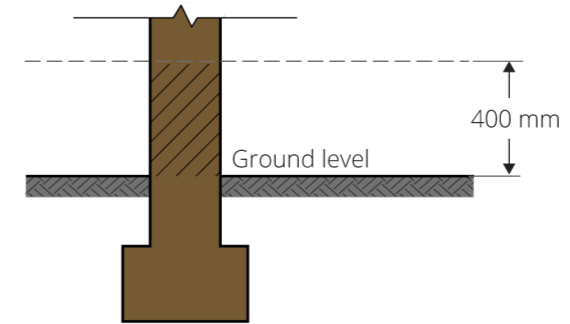

Figure 4 Construction requirements for external walls, glazing or door joinery within 400 mm of deck level.

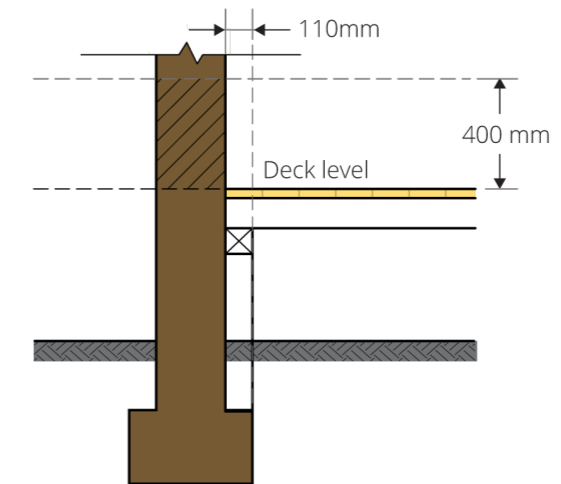
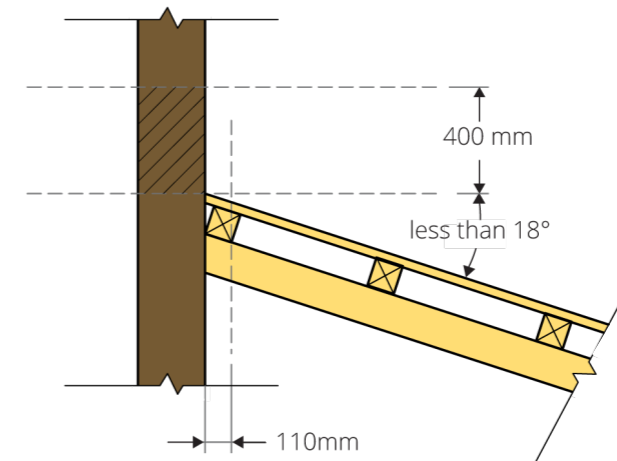

Figure 5 Construction requirements for external walls within 400 mm of carport, veranda or awning roof.



AGWA GUIDE SERIES

Compliance



Design Access and Mobility

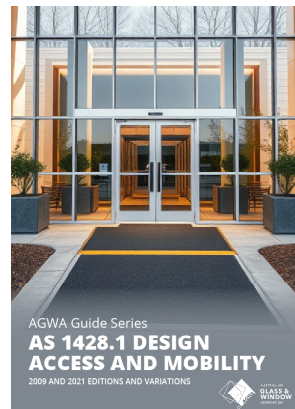

Energy Efficiency



Glass and Glazing

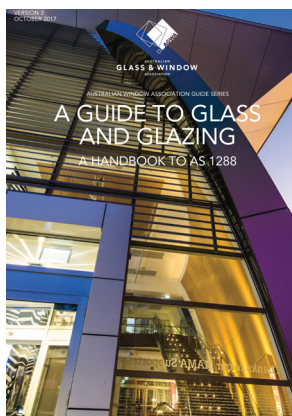

Window and Door Selection

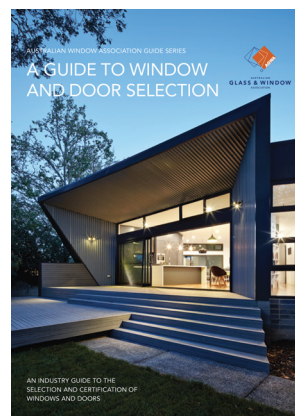

Document No. AGWA2018/BUSV6.0

Copyright © 2025 Australian Glass and Window Association. All Rights Reserved.

a: Pymble Corporate Centre, Suite 101B, Level 1, Building 1, 20 Bridge Street, Pymble NSW 2073

t: +61 2 9498 2768 e: admin@agwa.com.au w: www.agwa.com.au